

Este documento carece de validez contractual. Sólo válido a efectos informativos pudiendo ser modificado su contenido e información por razones técnicas, legales, comerciales u otras, sin previo aviso.
This document is not a deal or contract. It is only information and it can be changed by any technical, legal, business, or other reason without previous notice.

S50C

Cherry



PRE-GRADING of CHERRIES

by color, size and defects



USA Phone: (360)201-7162
CAN Phone: (604)855-8062
Email: info@fruittek.com



S50C Cherries

Pre-grading of cherries by size, color and defects.

Main features:

- Robustness and high reliability:
 - Electronics in a sealed air-conditioned cabinet.
 - Controlled by a single PC.
- Simple handling:
 - Touch screen.
 - Multiscan proprietary software.
- Sorting capabilities:
 - Optimum solution for pre-grading or re-packing.
 - Dual rotation mechanism.
 - Ejection system with 3 or 4 exits.
 - Water or belt infeed.
- Ease of maintenance:
 - Remote Personal Assistant.
 - Easy cleaning.
- Multiscan commitment:
 - Lowest cost of acquisition and maintenance in the market.

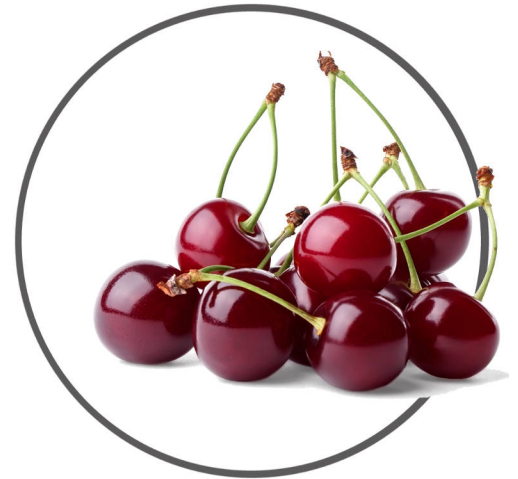

Boost your line throughput and reduce labor!
4 tons/h of high efficiency sorting in a very compact machine

Vision and LED lighting system



Rollers

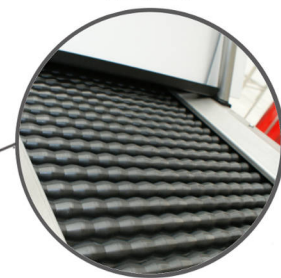

3 or 4-way output

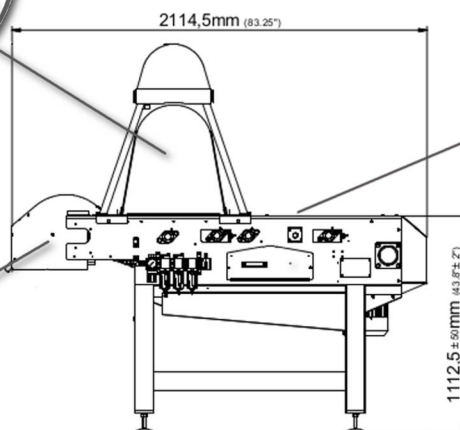

Technical parameters:

- Operating voltage: 230 Vac. ± 10% PH, 50/60Hz.
- Power: 4 kW.
- Air supply: up to 1,000 l / min for 35% ejection.
- Pneumatic Pressure connection / use: 8 bar / 6 bar.
- Weight: 770 kg.