

Este documento carece de validez contractual. Sólo válido a efectos informativos pudiendo ser modificado su contenido e información por razones técnicas, legales, comerciales u otras, sin previo aviso.  
This document is not a deal or contract. It is only information and it can be changed by any technical, legal, business, or other reason without previous notice.

# i5 Cherry Std Cherry



## SORTING and GRADING of CHERRIES by color, defects and size



USA Phone: (360)201-7162  
CAN Phone: (604)855-8062  
Email: info@fruittek.com



# i5 Cherry Std

Sorting and grading of cherries by color, defects and size

## Main features:

- Robustness and high reliability:
    - Electronics in a sealed air-conditioned cabinet.
    - Controlled by a single PC.
  - Simple handling:
    - Touch screen.
    - Multiscan proprietary software.
  - Sorting capabilities:
    - Defect sorting and grading.
    - Ejection system with 12 exits.
  - Easy of maintenance:
    - Remote Personal Assistant.
    - Easy cleaning.
  - Multiscan commitment:
    - Lowest cost of acquisition and maintenance in the market.
- Capable of handling dry and water flow processing

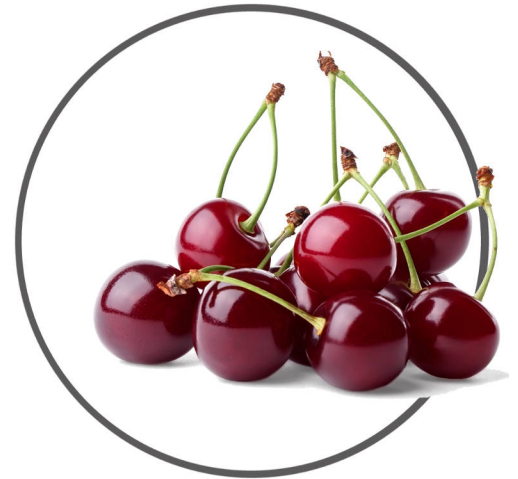

4 lanes and 2,000 kg/h capacity

Product infeed and alignment

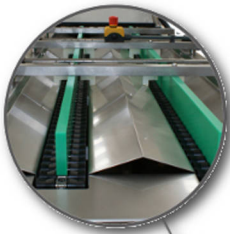

Vision and LED lighting system

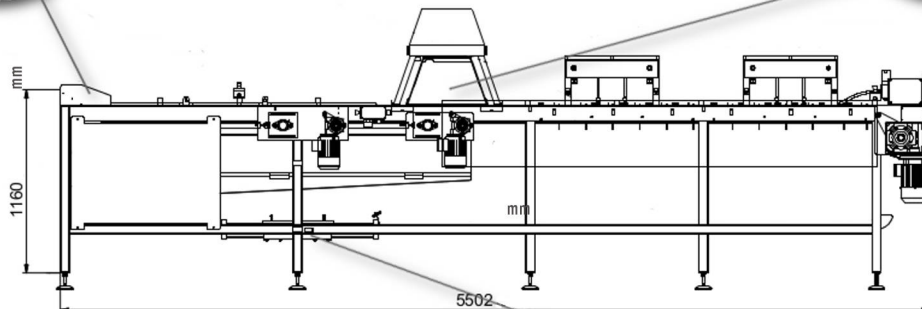
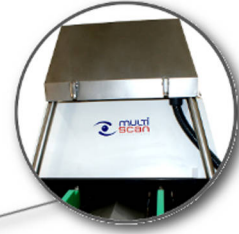

Chain cleaning system

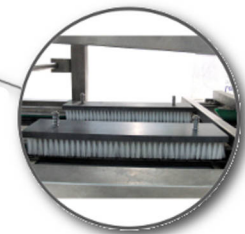

## Technical Parameters

- Operating voltage: 230 Vac.  $\pm$  10% PH, 50/60Hz
- Power: 4 kW.
- Air supply: 1,500 l / min.
- Pneumatic Pressure connection / use: 6 bar / 4 bar.
- Weight: 770 kg